



# SERIES AP 1400T

## TIED DIAPHRAGM REGULATOR

Intermediate to high flow applications

- Single stage
- Stainless steel 316L VAR secondary remelt construction
- Absolute sub-atmospheric option, flow rate to 6 slpm
- Cylinder or point of use specialty and bulk gases
- Flow rates to 600 slpm (21 scfm)
- Vacuum to 2,300 psig (159 bar) inlet HR option to 3,000 psig (207 bar)
- Designed and manufactured exclusively for UHP semiconductor applications
- Knob LOTO option (refer to AP KL data sheet)
- Installation and operating instructions available at [www.aptech-online.com](http://www.aptech-online.com)

### Operating Parameters

Source pressure	AP 1400T	vacuum to 2,300 psig (159 bar)
	AP 1400TA	vacuum to 300 psig (21 bar)
	AP 1400T HR	vacuum to 3,000 psig (207 bar)
Delivery pressure	AP 1402TA	100 mm Hg absolute to 30 psig (2 bar) <small>(not available for HR)</small>
	AP 1402T	1 to 30 psig (0.07 to 2 bar) <small>(not available for HR)</small>
	AP 1406T	1 to 60 psig (0.07 to 4 bar) <small>(not available for HR)</small>
	AP 1410T	2 to 100 psig (0.14 to 7 bar)
	AP 1415T*	5 to 150 psig (.34 to 10 bar)
Proof pressure		150% of operating pressures
Burst pressure		300% of operating pressures

\*AP 1415T will not achieve full outlet pressure rating at all inlet pressures.

### Other Parameters

Inlet/outlet connectors	1/4, 3/8 or 1/2 inch face seal or tube weld
Bonnet port	1/8 inch NPT
Flow coefficient (Cv)	0.45
Internal volume	1.06 in <sup>3</sup> (17.4 cm <sup>3</sup> )
Operating temperature	-40° to +160°F (-40° to +71°C)**
Surface finish	15 µin Ra max / 10 µin. Ra avg. (0.4/0.25 µm) standard; 10 µin (0.25 µm); 7 µin (0.18 µm); and 5 µin (0.13 µm) Ra max optional
Inboard leakage	2 x 10 <sup>-10</sup> sccs
Outboard leakage	2 x 10 <sup>-9</sup> sccs He
Leakage across seat	4 x 10 <sup>-8</sup> sccs He
Installation	surface or panel (optional)
Supply pressure effect	1.6 psig per 100 psig source pressure change

\*\*VS option 14° to 194°F (-10° to + 90°C).

### Materials

	Series AP 1400T S Corrosive	Series AP 1400T SH Corrosive
Type of Service		
Wetted Parts		
Body	SS 316L secondary remelt	SS 316L secondary remelt
Poppet and diaphragm	Ni-Cr-Mo alloy / UNS N06022	Ni-Cr-Mo alloy / UNS N06022
Nozzle	SS 316L	Ni-Cr-Mo alloy / UNS N06022
Finish	electropolished and passivated	electropolished and passivated
Seat	PCTFE (Polyimide optional)	PCTFE

All specifications subject to change without notice.

# ULTRACLEAN BY DESIGN

## DIMENSIONAL INFORMATION

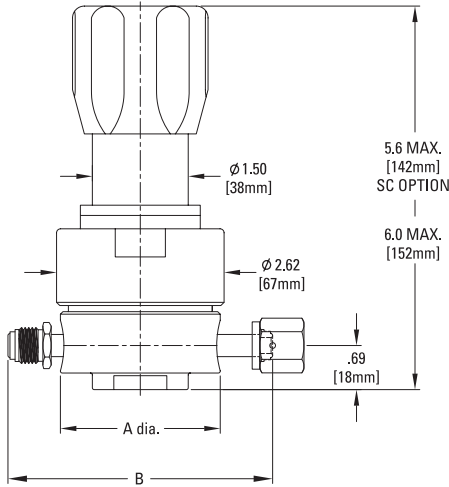

Face Seal	A	B
1/4" Male	2.00" (51 mm)	4.00" ±.02 (102 mm)
1/4" Female	2.00" (51 mm)	3.70" ±.02 (94 mm)
3/8"	2.50" (64 mm)	5.22" ±.03 (133 mm)
1/2"	2.50" (64 mm)	5.22" ±.03 (133 mm)

All dimensions in inches (mm). Metric dimensions are for reference only.

## PORTING CONFIGURATIONS

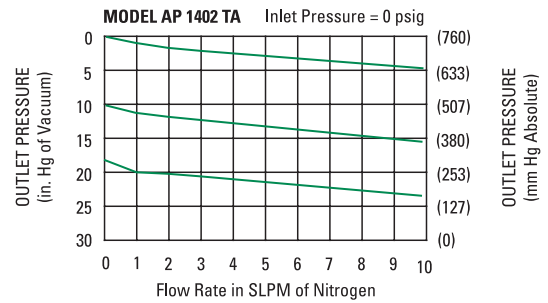
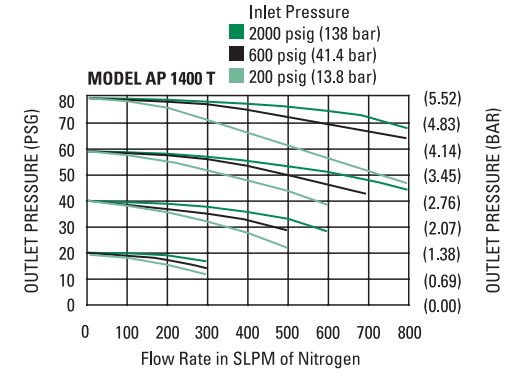
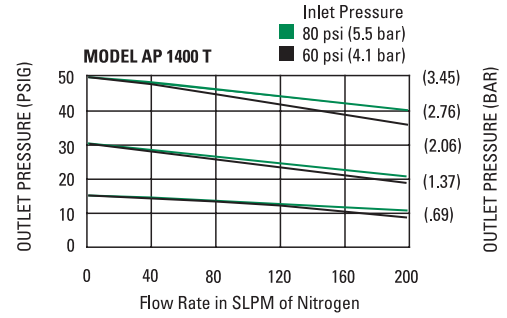
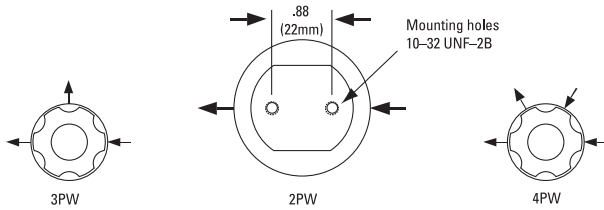

**CAUTION:** Product selection is the sole responsibility of the user, regardless of any recommendations or suggestions made by the factory. The user shall make selections based upon their own analysis and testing with regard to function, material compatibility and product ratings. Proper installation, operation and maintenance are also required to assure safe, trouble free performance.

## ORDERING INFORMATION

Sample Order Number	AP 1402TSMa 3PW FV4 FV4 V3	
<b>AP 1402T   Series</b>	AP 1402T = 1-30 psig (.07 to 2 bar)	<b>FV4 FV4   Connections Inlet / Outlet</b>
	AP 1406T = 1-60 psig (.07 to 4 bar)	FV4 = 1/4 inch face seal female
	AP 1410T = 2-100 psig (.14 to 7 bar)	MV4 = 1/4 inch face seal male
<b>S   Material</b>	S = Stainless steel (SHP)*	FV6 = 3/8 inch face seal female
	SH = SS/Ni-Cr-Mo alloy internals	MV6 = 3/8 inch face seal male
<b>M   Surface Finish Options</b>	M = 10 μin. Ra max	FV8 = 1/2 inch face seal female
	V = 7 μin. Ra max	MV8 = 1/2 inch face seal male
	X = 5 μin. Ra max	Tube weld stub available
<b>A   Range Options</b>	A = 100 mm Hg absolute to 30 psig (2 bar) (AP 1402T option only)	<b>V3   Gauges Source / Delivery</b>
<b>3PW   Ports</b>	2PW = 2 ports butt weld face seal	0 = No gauge
	3PW = 3 ports butt weld face seal	V3 = 30-0-30 psig/bar
	4PW = 4 ports butt weld face seal	L = 30-0-60 psig/bar
		1 = 30-0-100 psig/bar
		2 = 0-200 psig/bar
		4 = 0-400 psig/bar
		10 = 0-1000 psig/bar
		40 = 0-4000 psig/bar
		<b>Options</b>
		P = Panel installation ring
		VS = Polyimide seat
		HR = High inlet pressure
		SC = Short bonnet*
		KL = Knob LOTO*

AP Tech has product options and variations which are not documented in data sheets. If you have a model number that is not defined by the ordering information, please consult the factory or your local representative.

\*S equivalent to SHP – stainless steel with Ni-Cr-Mo alloy poppet and diaphragm

Standard gauge ports are 1/4 inch face seal male. (1/4 inch face seal female are available).

On panel mount option, bonnet port is not threaded. Panel hole 1.56" diameter

\*SC option not available with 1402TA option. KL should be ordered with SC option.